

Sistema di contenitore per pezzi piccoli - Caratteristiche del prodotto



Maniglie ergonomiche per un trasporto sicuro



Vassoio multifunzionale (ad esempio, può essere utilizzato come portautensili o portapezzi)

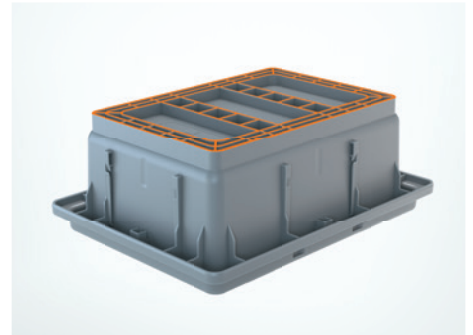

Fondo scorrevole ottimo per l'utilizzo su rulliere



Impilabili l'uno sull'altro con un profilo appositamente studiato per avere una grande capacità di riempimento



Presenza ottimale per il robot

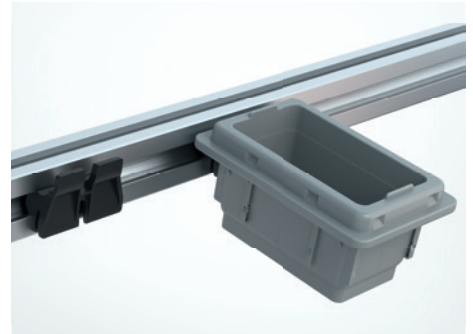

Portascatole nella gamma degli accessori

Soluzione - ideale per l'utilizzo con MBS PickStar

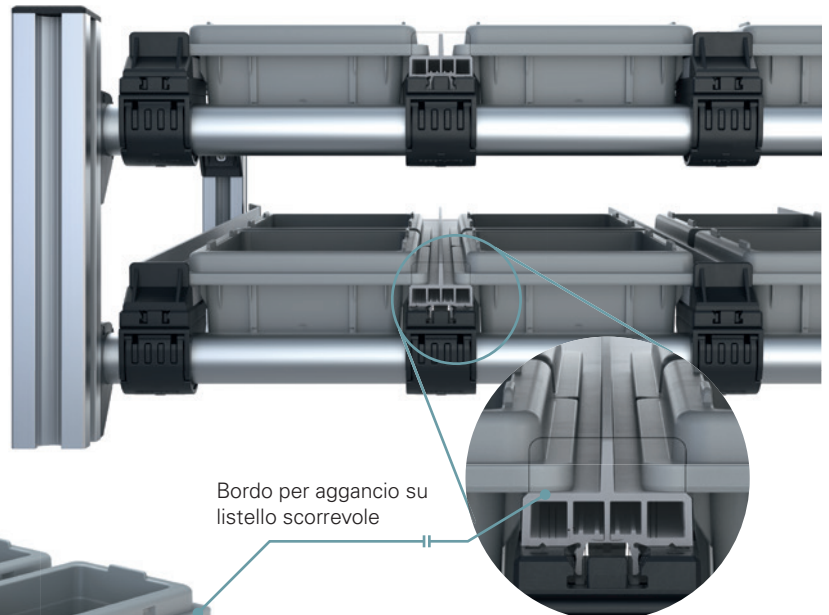

Due misure standard combinabili

Bordo per aggancio su listello scorrevole



Etichette possono essere attaccate sui 4 lati



Anche in versione ESD

Vassoio - Caratteristiche del prodotto

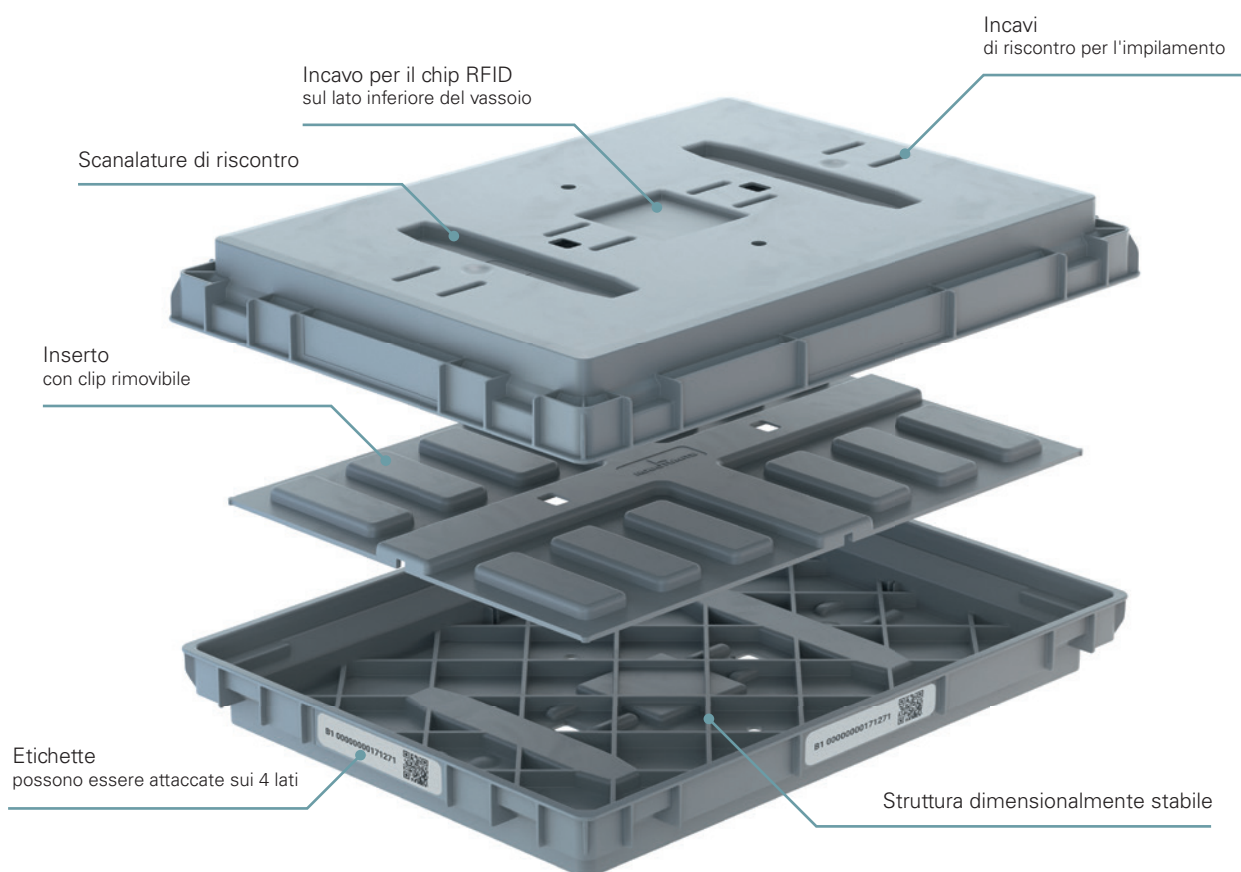

Impilabile - dal vassoio all'europallet

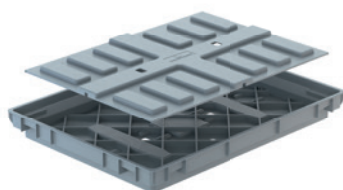

Vassoio con inserto



Vassoio con inserto riempito



Vassoio utilizzato come piano intermedio



Piano intermedio riempito



Vassoio utilizzato come coperchio

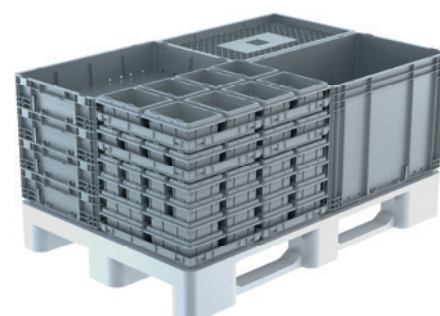

Europallet



Contenitore 150x100x75



Contenitore 200x150x75

Applicazione

Contenitore per pezzi piccoli, compatibile con tutta la gamma del sistema di contenitori Robotunits:

- stabile
- automatizzabile
- impilabile
- ergonomico
- Etichette sui 4 lati
(possono essere inserite o incollate)

Dati tecnici

Materiale: PP, ESD su richiesta

Resistenza alla temperatura:

-da 20°C a +60°C,
per breve tempo anche +75°C

Carico utile

150x100 = 2,2 kg

200x150 = 4,4 kg

Carico impilabile

100 kg

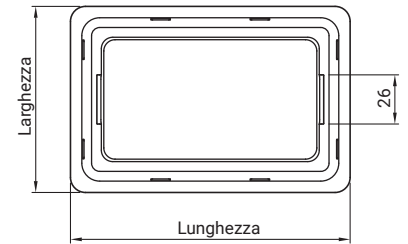
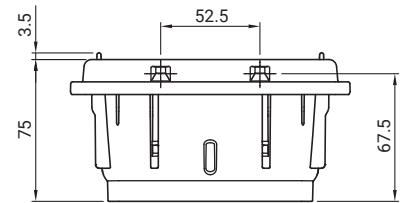
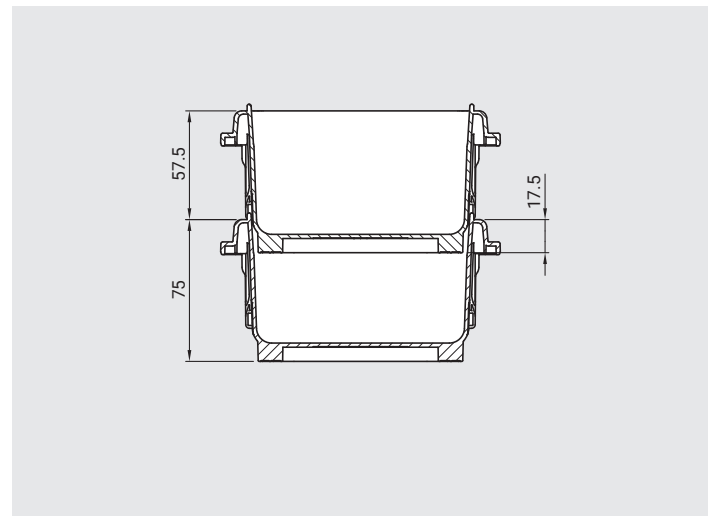
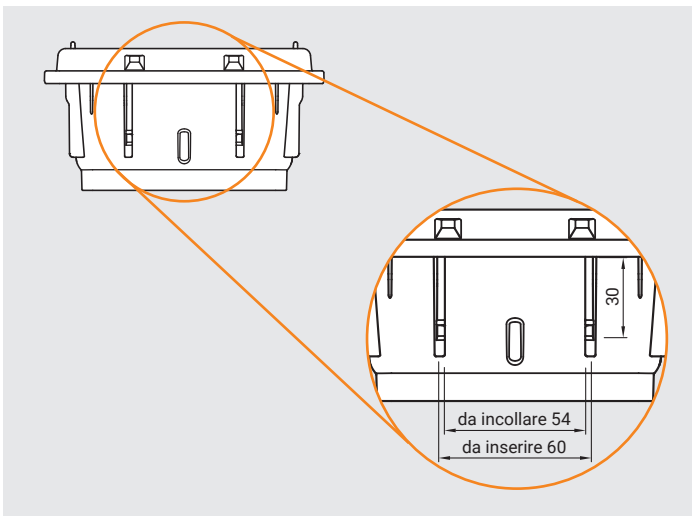
**Dimensioni delle etichette****Dimensioni contenitori impilati****Codice d'ordine**

Descrizione	Dim. esterne		Dim. interne		Volume Litri	Codice d'ordine	Peso/pezzo
	Lungh.	Largh.	Lungh.	Largh.			
Contenitore 150x100x75, conf. da 112 pezzi	148	98	110	60	0,45	BOX1510PAC0112	0,100 kg
Contenitore 200x150x75, conf. da 56 pezzi	198	148	160	110	1,18	BOX2015PAC0056	0,170 kg

Disegni: le misure sono espresse in mm

BOX 403_

Vassoio 400x300 / Inserto 400x300



Vassoio 400x300

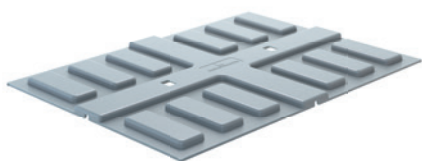

Inserto 400x300



Vassoio con inserto 400x300

Applicazione

Vassoio compatibile con tutta la gamma del sistema di contenitori Robotunits

- stabile
- automatizzabile
- impilabile
- inserto sostituibile
- bassa rumorosità sulle rulliere
- Incavo sui lati e sul fondo per codice di riconoscimento (ad es. Datamatrix)
- Scanalature sul tappo
- Aperture per il drenaggio dell'acqua

Dati tecnici

Materiale: PP, possibilità di ESD

Resistenza alla temperatura:

-da 20°C a +60°C,
per breve tempo anche +75°C

Carico utile

17,5 kg

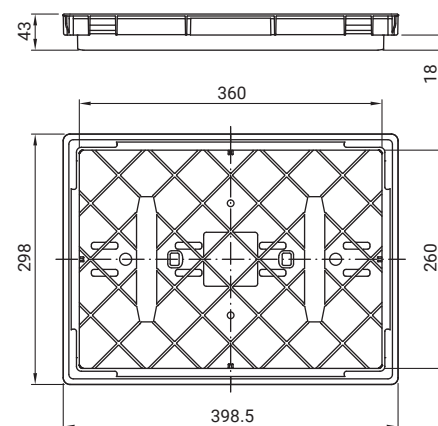
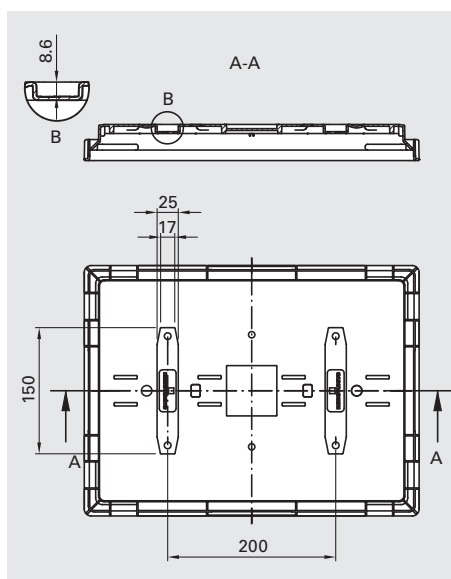
Scanalatura sul tappo

Vassoio 400x300

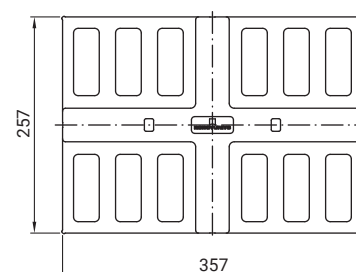
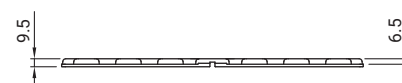

Inserto 400x300

Codice d'ordine

Descrizione	Codice d'ordine	Peso/pezzo
Vassoio 400x300, conf. da 264 pezzi	BOX4030PAC0264	0,455 kg
Inserto 400x300, conf. da 264 pezzi	BOX4031PAC0264	0,335 kg

Disegni: le misure sono espresse in mm